

1

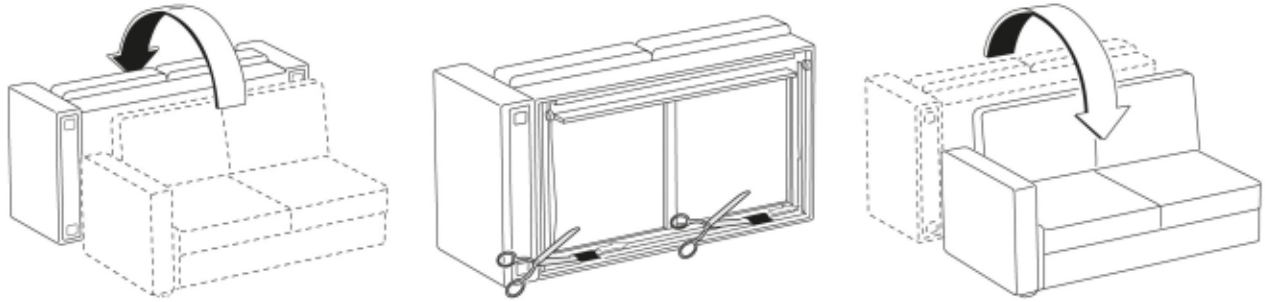

2

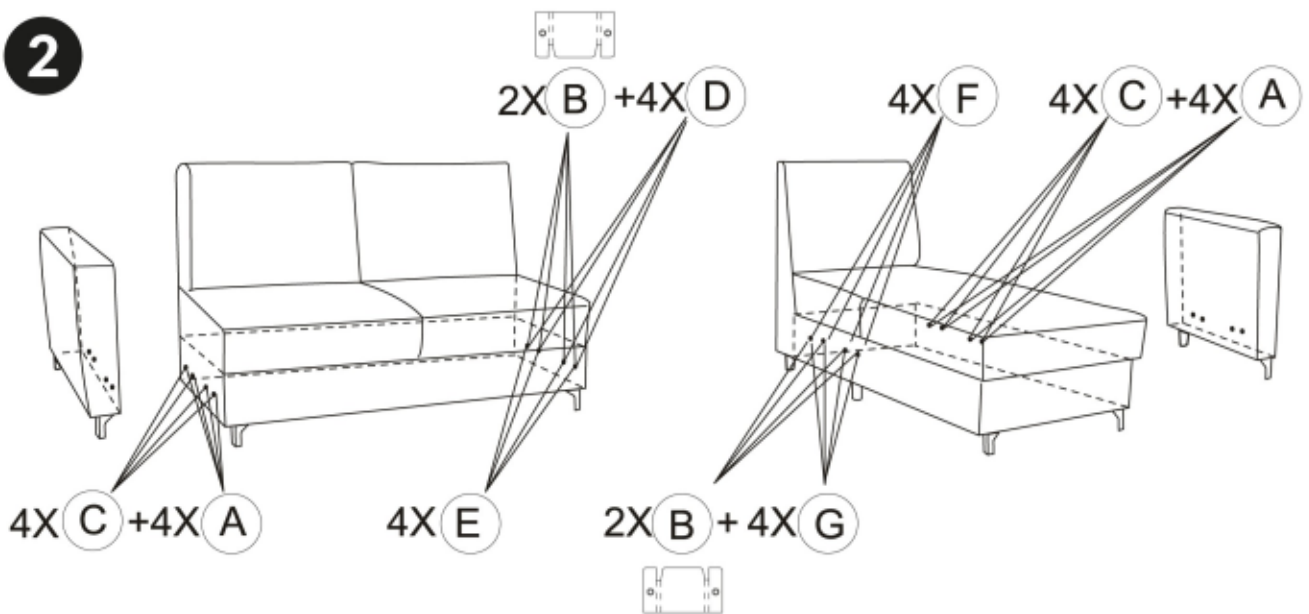

3

LEWY / LEFT



PRAWY / RIGHT

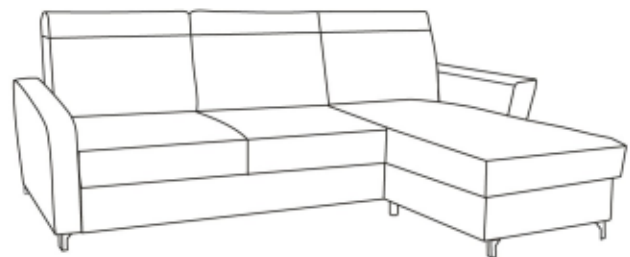

NARZĘDZIA / TOOLS



x1

ELEMENTY ŁĄCZĄCE / HARDWARE



Ax8



Bx4



Cx8



Dx4



Ex4



Fx4



Gx4

CZAS / TIME MONTAŻ / INSTALLATION



30 min



2 osoby